

Level 3 Aviation Exam Review

Subjects Covered

- PO 331 – Describe Principles of Flight
- PO 336 – Identify Meteorological Conditions
- PO 337 – Demonstrate Air Navigation Skills
 - Technically part of the subject group, but not actually included in the exam

PO 331 - Describe Principles of Flight

- 01 – Describe Aircraft Stability

PO 331.01 - Describe Aircraft Stability

- **Stability**
 - Tendency of an aircraft to remain in straight, level, upright flight and to return to this attitude, if displaced, without corrective action
- **Static Stability**
 - Initial tendency of an aircraft to return to its original attitude, if displaced
- **Dynamic Stability**
 - Overall tendency of an aircraft to return to its original attitude

PO 331.01 - Con't

- **Positive Stability**
 - The aircraft is able to return to its original attitude without any corrective measure
- **Neutral Stability**
 - The aircraft will remain in the new attitude of flight after being displaced
- **Negative Stability**
 - The aircraft will continue moving away from its original attitude after being displaced

PO 331.01 - Con't

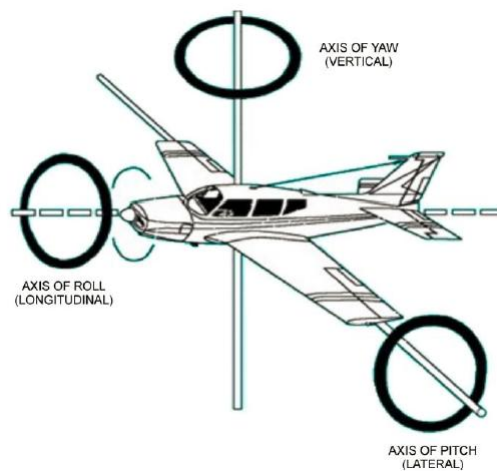

PO 331.01 - Con't

- Longitudinal Stability (pitch stability)
 - Stability around the lateral axis
 - Influencing factors:
 - Horizontal Stabilizer
 - Centre of Gravity

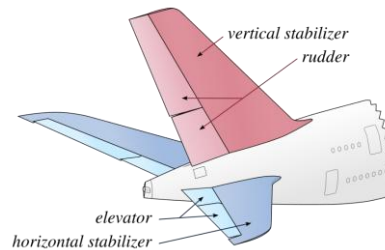

PO 331.01 - Con't

- Lateral Stability (roll stability)
 - Stability around the longitudinal axis
 - Maintained through the following design features:
 - Dihedral
 - Angle that the wings make with the horizontal plane
 - Sweepback
 - The wings sweep back instead of protruding straight
 - Keel Effect
 - High wing aircraft → most of the weight is below the wings, which acts like a pendulum

PO 331.01 - Con't

- Directional Stability
 - Stability around the vertical axis
 - Influenced by the vertical tail surface

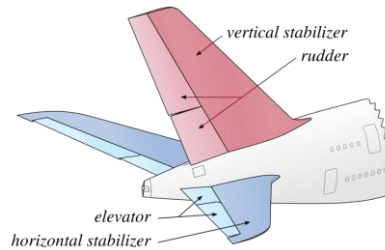

PO 336 - Identify Meteorological Conditions

- 01 – Describe Properties of the Atmosphere
- 02 – Explain the Formation of Clouds
- 03 – Explain the Effects of Air Pressure on Weather
- 04 – Explain the Effects of Humidity and Temperature on Weather

PO 336.01 - Describe Properties of the Atmosphere

- The atmosphere is primarily composed of nitrogen (78%), oxygen (21%), argon, carbon dioxide, hydrogen, and water vapour
- Water vapour is only found in the lower layers
 - It is the most important gas from the standpoint of weather

PO 336.01 - Con't

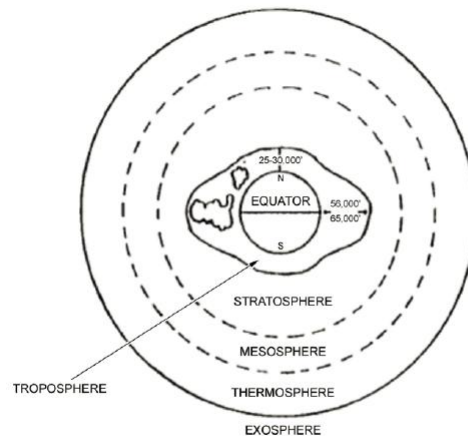

A. F. MacDonald and I. L. Pepler, *From the Ground Up*, Aviation Publishers Co. Limited (p. 123)

Figure 13-1-1 The Four Layers of the Atmosphere

PO 336.01 - Con't

- Properties of the Atmosphere
 - Mobility
 - Ability of air to move from one place to another
 - Capacity for Expansion
 - Most Important Property!
 - Air is forced to rise for various reasons
 - As it rises, air pressure decreases, so the air expands and cools
 - Cooling may be enough for condensation to occur and clouds to form
 - Capacity for Compression
 - Opposite of Capacity for Expansion

PO 336.01 - Con't

- Properties of the Atmosphere
 - The following are the factors that affect the properties in the atmosphere:
 - Temperature
 - Density
 - Pressure

PO 336.02 - Explain the Formation of Clouds



*"Victoria Weather", by UVic, School-Based Weather Station Network.
Retrieved November 1, 2007, from <http://www.victoriaweather.ca/clouds>*

Figure 13-2-1 Cumulus Cloud

Formed in unstable air. Are cottony/puffy and seen mostly during warmer seasons. May develop into storm clouds.

PO 336.02 - Con't



*"Victoria Weather", by UVic, School-Based Weather Station Network.
Retrieved November 1, 2007, from <http://www.victoriaweather.ca/clouds>*

Figure 13-2-2 Stratus Cloud

Formed in stable air. Are flat and seen year round, but are associated with colder temperatures.

PO 336.02 - Con't

- **Cloud Height**
 - **Low**
 - Composed of water droplets, sometimes ice crystals
 - **Middle**
 - Composed of water droplets and ice crystals
 - **High**
 - Composed of ice crystals
 - **Clouds of Vertical Development**
 - Associated with thunder storms and other summer month phenomena

PO 336.02 - Con't - Air Stability

Stable Air Characteristics

- Poor low-level visibility
- Stratus type clouds
- Steady precipitation
- Steady winds, which can change greatly with height
- Smooth flying conditions

Unstable Air Characteristics

- Good visibility (except in precipitation)
- Cumulus type clouds
- Showery precipitation
- Gusty winds
- Moderate to severe turbulence

PO 336.02 - Con't

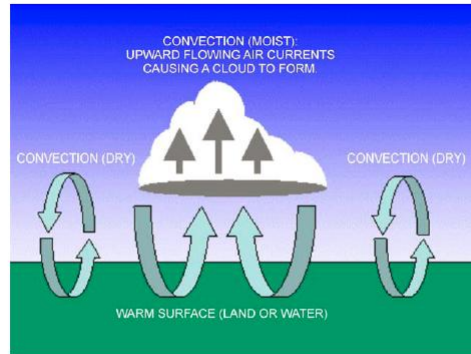

WeatherQuestions.com, 2007, What is Convection. Copyright 2007 by WeatherStreet. Retrieved March 17, 2008, from http://www.weatherquestions.com/What_is_convection.htm

Figure 13-2-4 Convection

PO 336.02 - Con't

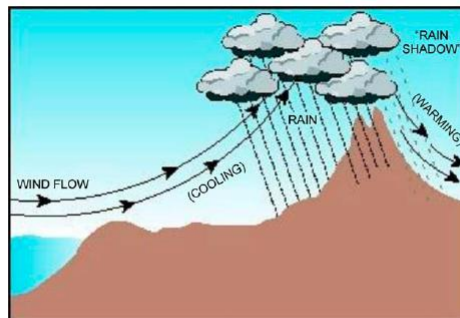

Water Encyclopedia, by G. H. Taylor, 2007, Water as a Climate Moderator. Copyright 2007 by Advameg. Retrieved March 17, 2008, from <http://www.waterencyclopedia.com/Ce-Cr/Climate-Moderator-Water-as-a.html>

Figure 13-2-5 Orographic Lift

PO 336.02 - Con't

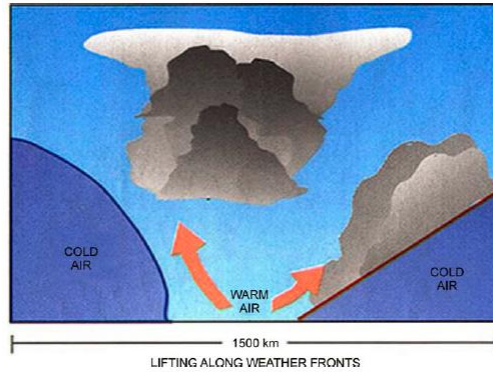

Federation of American Scientists, by N. M. Short, Sr, 2007, *Atmospheric Circulation: Weather Systems*. Copyright 2007 by FAS. Retrieved March 17, 2008, from http://www.fas.org/irp/mint/docs/rst/Sect14/Sect14_1c.html

Figure 13-2-6 Frontal Lift

PO 336.02 - Con't

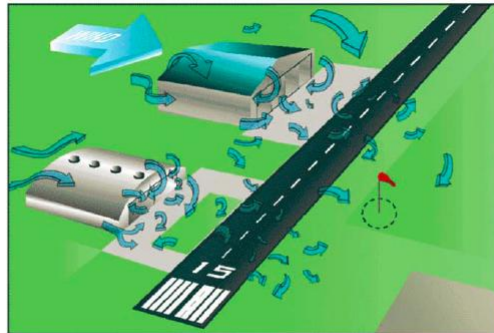

Free Online Private Pilot Ground School, 2006, *Aviation Weather—Principles*. Copyright 2006. Retrieved March 17, 2008, from <http://www.free-online-private-pilot-ground-school.com/Aviation-Weather-Principles.html>

Figure 13-2-7 Mechanical Turbulence: Man-Made

PO 336.02 - Con't

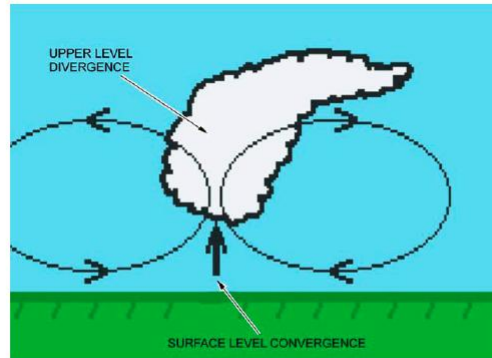

The Weather Doctor, by K. C. Heidron, PhD, 2002, What Goes Up: Part 3 Convergence and Divergence. Retrieved March 17, 2008, from <http://www.islandnet.com/~see/weather/elements/whatgoesup3.htm>

Figure 13-2-8 Convergence

PO 336.03 - Explain the Effects of Air Pressure on Weather

- Isobars
 - Lines joining areas with the same air pressure
 - Looks similar to contour lines on a map
- Low Pressure Areas
 - Associated with thunderstorms, tornadoes, and brief periods of poor weather
 - Don't stay in one place for very long
 - In Northern Hemisphere, air moves in a counter-clockwise motion
- High Pressure Areas
 - Move slowly
 - Associated with fair weather
 - In Northern Hemisphere, air moves in a clockwise motion

PO 336.03 - Con't

- **Air Mass**
 - Large section of the troposphere with uniform temperature and moisture along a horizontal plane
 - Takes on the properties of the surface over which it has formed
 - Eg) an Arctic air mass is typically cold and dry

PO 336.03 - Con't

- **Wind**
 - Horizontal movement of air within the atmosphere
 - Normally moves parallel to isobars of pressure
- **Pressure Gradient**
 - Rate of change of pressure over a given distance

PO 336.03 - Con't

SEA BREEZE CIRCULATION

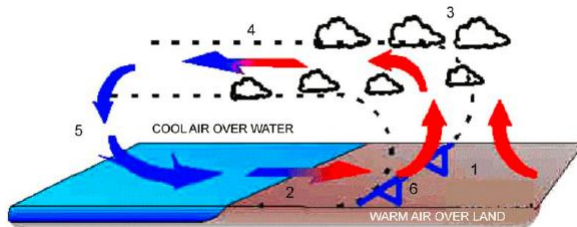

Occurs during the day when the water heats up faster than the land.

LAND BREEZE CIRCULATION

Occurs during the night when the land cools down faster than the water

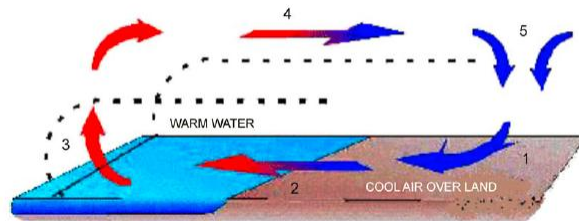

PO 336.04 - Explain the Effects of Humidity and Temperature on Weather

- **Humidity**
 - A representation of the water vapour in the air
- **Condensation**
 - Process by which a gas changes into a liquid
- **Sublimation**
 - Process by which a gas changes into a solid
 - Eg) when snow, ice, or hail are formed
- **Dew Point**
 - Temperature at which unsaturated air must be cooled, at a constant pressure, in order for it to become saturated
- **Relative Humidity**
 - Actual amount of water present in the air compared to the amount of water which the same volume of air would hold if it was saturated

PO 336.04 - Con't

- **Temperature**
 - **Most of the heat in the atmosphere is radiated heat from the earth**
 - Radiation from the sun is the main heat source for the earth's surface

PO 336.04 - Con't

- **Heating Processes**
 - **Convection**
 - Air over a warm surface becomes buoyant and rises, allowing cooler air to move into the vacant location below
 - **Advection**
 - Horizontal movement of cool air over a warm surface heats the air
 - **Turbulence**
 - Causes a mixing process that moves heated air to other areas of the atmosphere
 - **Compression**
 - When air masses are forced downward, the compression generates heat

PO 336.04 - Con't

- **Cooling Processes**
 - **Radiation Cooling**
 - At night, the temperature of the earth decreases and cools the air in contact with the ground
 - **Advection Cooling**
 - Air from a warm region moves over a cold region, thus cooling the air
 - **Adiabatic Process**
 - As air is warmed it rises and will expand to cool

PO 336.04 - Con't

- **Types of Precipitation**
 - Drizzle
 - Rain
 - Hail
 - Snow Pellets
 - Snow
 - Ice Prisms
 - Ice Pellets